



USB-C Hybrid Dock

User Manual

Copyright and disclaimer

Copyright

Copyright 2024 BenQ Corporation. All rights reserved. No part of this publication may be reproduced, transmitted, transcribed, stored in a retrieval system or translated into any language or computer language, in any form or by any means, electronic, mechanical, magnetic, optical, chemical, manual or otherwise, without the prior written permission of BenQ Corporation.

Disclaimer

BenQ Corporation makes no representations or warranties, either expressed or implied, with respect to the contents of this document. BenQ Corporation reserves the right to revise this publication and to make changes from time to time in the contents thereof without obligation to notify any person of such revision or changes.

This document aims to provide the most updated and accurate information to customers, and thus all contents may be modified from time to time without prior notice. Please visit the website for the latest version of this document.

HDMI trademark disclaimer

The terms HDMI and HDMI High-Definition Multimedia Interface, and the HDMI Logo are trademarks or registered trademarks of HDMI Licensing Administrator, Inc. in the United States and other countries.



Product support

This document aims to provide the most updated and accurate information to customers, and thus all contents may be modified from time to time without prior notice. Please visit the website for the latest version of this document and other product information. Available files vary by model.

1. Make sure your computer is connected to the Internet.
2. Visit the local website from Support.BenQ.com. The website layout and content may vary by region/country.

Search for your model's user manual and related document.

Servicing

- If misuse or other accident occurs, contact qualified service personnel for servicing.
- Contact your place of purchase or visit the local website from Support.BenQ.com for more support.

Table of contents

Copyright and disclaimer	i
Product support.....	ii
Overview	1
Package contents.....	1
Compatibility.....	1
Safety precautions.....	1
Port overview	2
Setting up your docking station	3
1. Installing DisplayLink® driver.....	3
2. Connecting displays.....	3
Supported max resolution	4
3. Connecting dual inputs.....	4
4. Powering on/off.....	5
LED indicator	5
5. Switching input source.....	5
Other ports	6
USB-C 3.2.....	6
USB-A 3.2.....	6
USB-A 2.0.....	6
Ethernet.....	7
Audio in & out.....	7
Product information.....	8
Specifications	8
Troubleshooting	10
Charging & power issue.....	10
Internet issue.....	10
Cable issue	11
DisplayLink issue	11
Audio issue.....	11
Video issue.....	12

Overview

Package contents



DP1310 USB-C Hybrid Dock
(with rubber feet)



BenQ HDMI 2.1 cable



BenQ USB-C cable



Power adapter



Power cord



Quick start guide



Marketing card



Safety statements



Warranty card

Compatibility

Operating system requirements:

- Windows: 10+
- macOS: 11.5+
- Linux: Ubuntu 14.04+
- Android: 5.0+
- ChromeOS: R55 Build+

Safety precautions

1. Avoid dropping this product.
2. This product is not fully sealed; avoid contact with liquids.
3. If your DP1310 becomes wet while turned off, do not power it on, attempt repairs, or open the device.
4. Do not disassemble this product.
5. The ambient temperature during use must not exceed 40°C/104°F.
6. Keep this product away from open flames.
7. Clean this product only with a dry cloth or brush.
8. Use only the provided cable, power adapter, and power cord. Using other types of adapters may result in malfunction or hazard. Ensure the power adapter is connected to a proper outlet, and maintain adequate ventilation around the adapter.
9. Do not attempt to repair the power adapter yourself, as there are no user-serviceable parts inside. If the adapter is damaged or has been exposed to excessive moisture, contact your dealer for a replacement.

Port overview

Front view

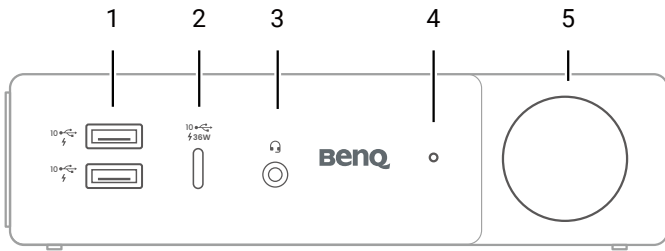

- 1. USB-A 3.2 Gen2**
10Gbps with BC1.2 7.5W charging
- 2. USB-C 3.2 Gen2**
10Gbps with PD 36W charging
- 3. 3.5 mm audio jack (IN & OUT)**

- 4. Status indicator**
See [LED indicator on page 5](#) for details.
- 5. Power & source switch button**
See [Powering on/off on page 5](#) and [Switching input source on page 5](#) for details.

Rear view

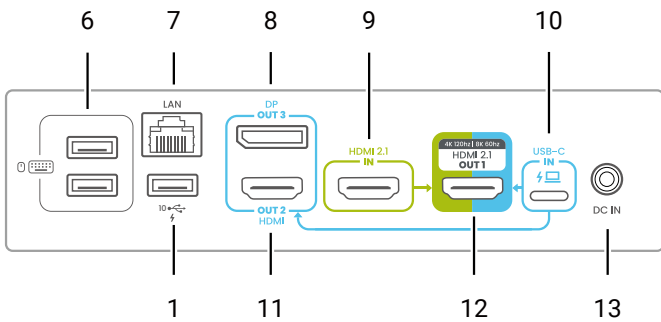

- 6. USB-A 2.0**
480Mbps (for keyboard & mouse)
- 7. Gigabit Ethernet**
- 8. DisplayPort 1.2 (OUT 3)**
- 9. HDMI 2.1 (IN)**

- 10. USB-C 3.2 Gen2 (IN)**
10Gbps with PD 100W charging
- 11. HDMI 2.0 (OUT 2)**
- 12. HDMI 2.1 (OUT 1)**
- 13. DC-IN**

Setting up your docking station

Follow the steps below to finish the initial set up or [learn how to set up the dock through video guide](#).

1. Installing DisplayLink® driver

Go to benqurl.biz/dock-driver to download the latest DisplayLink driver. Follow the website guide to complete your installation.

Note

You must download the driver in order to display up to three displays.

2. Connecting displays

You can add up to three external displays to this docking station, which features two HDMI out ports and one DP out port. Among the three out ports, only **HDMI 2.1 (OUT 1)** port can receive two input sources and toggle between sources with one button click.

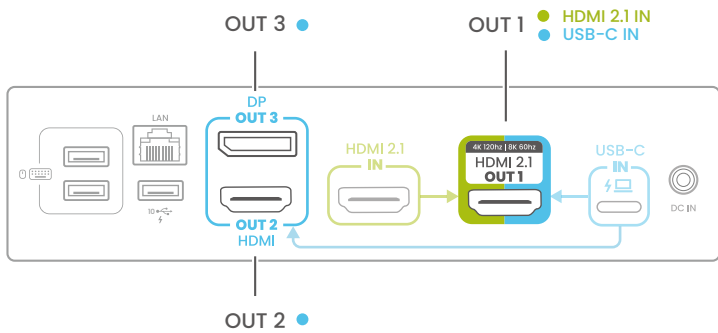

Step 1 Connect your primary display to the **HDMI 2.1 (OUT 1)** port with the provided BenQ HDMI cable.

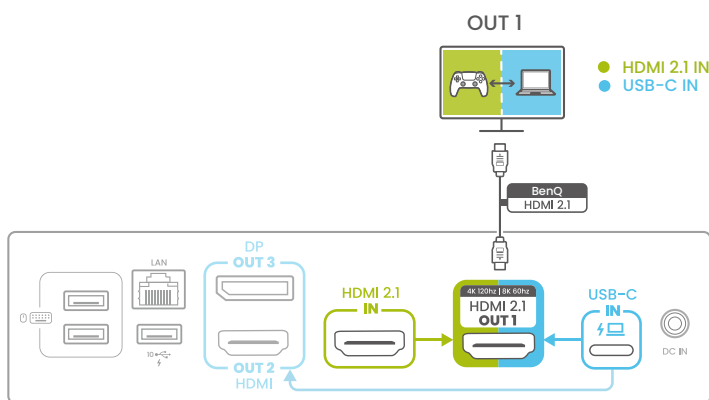

Step 2 Connect your secondary displays to the **HDMI (OUT 2)** and **DP (OUT 3)** ports.

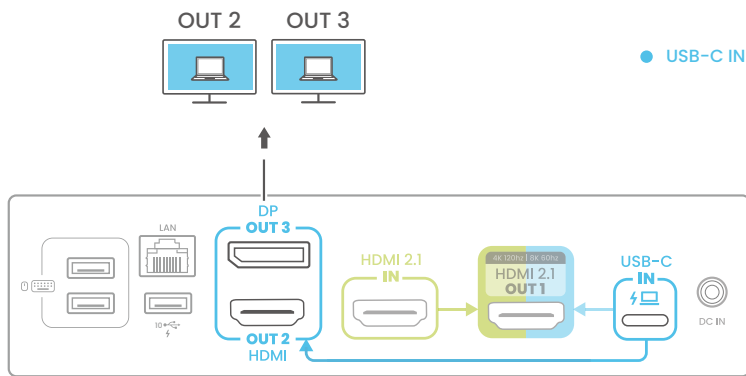

Supported max resolution

Output	HDMI 2.1 (OUT 1)	HDMI 2.0 (OUT 2)	DP 1.2 (OUT 3)
Input	HDMI 2.1 ↔ USB-C	USB-C	USB-C
Single display	8K 60Hz ↔ 4K 60Hz	-	-
	-	4K 60Hz	-
	-	-	4K 60Hz
Dual displays	8K 60Hz ↔ 4K 60Hz	4K 60Hz	-
	8K 60Hz ↔ 4K 60Hz	-	4K 60Hz
	-	4K 60Hz	4K 60Hz
Triple displays	8K 60Hz ↔ 4K 60Hz	4K 60Hz	4K 60Hz

3. Connecting dual inputs

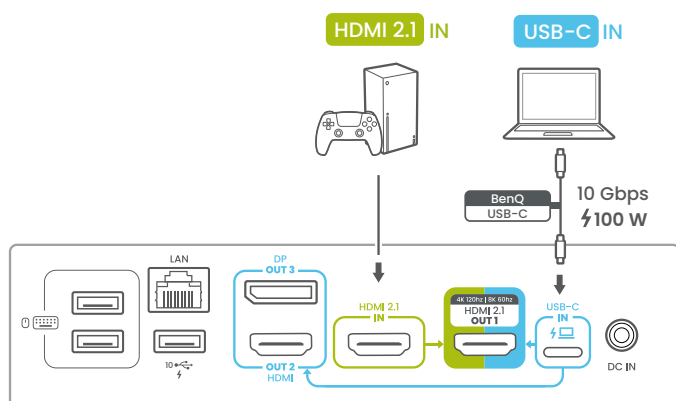

Step 1 Connect your gaming console or PC to the **HDMI 2.1 IN** port with a HDMI cable.

Step 2 Connect your laptop to the **USB-C IN** port with the provided BenQ USB-C cable. The USB-C port provides charging up to 100W for your laptop.

4. Powering on/off

Step 1 Plug one end of the provided adapter into the **DC-IN** port and the other into a power outlet.

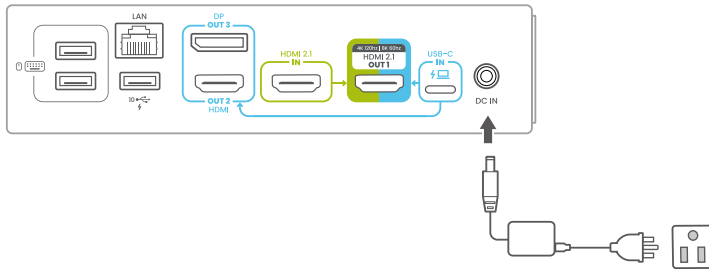

Step 2 Press the power button at the front for three seconds to power on.



LED indicator

LED behavior	Status description
Off	Powered off
Flashing white	Powering on/off
Solid white	Standby
Flashing blue	Searching for USB-C IN source (e.g. laptop)
Solid blue	Connected to USB-C IN source (e.g. laptop)
Flashing green	Searching for HDMI 2.1 IN source (e.g. gaming console/PC)
Solid green	Connected to HDMI 2.1 IN source (e.g. gaming console/PC)

5. Switching input source

Press the round button to switch the input source of your main display (OUT1). Once the source is switched to USB-C, the LED turns blue. When switching to HDMI 2.1, the LED turns green.

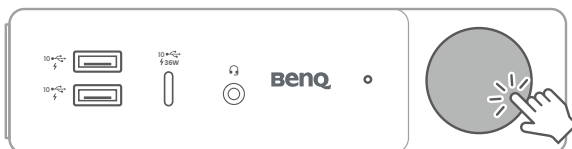

Other ports

USB-C 3.2

Connect any USB-C compatible devices to the USB-C 3.2 port. The port provides 36W charging and data transfer speeds of 10 Gbps.

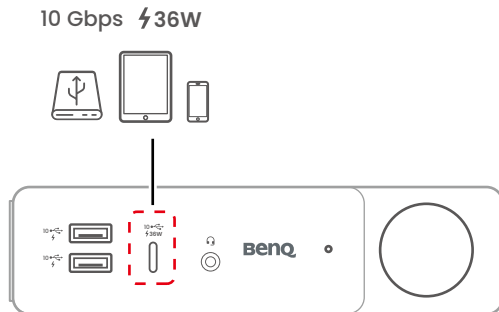

USB-A 3.2

The product features a total of three USB-A 3.2 ports, supporting 7.5W charging and data transfer speeds of 10 Gbps.

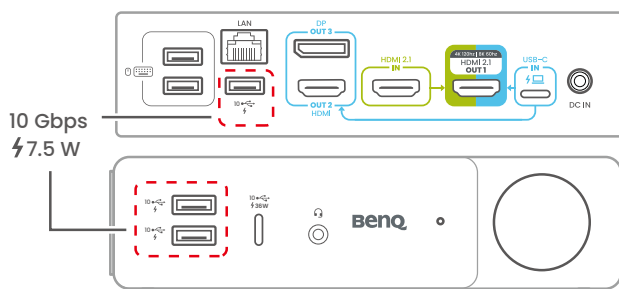

USB-A 2.0

Connect your keyboard & mouse to the USB-A 2.0 port. The port supports data transfer speeds of 480 Mbps.

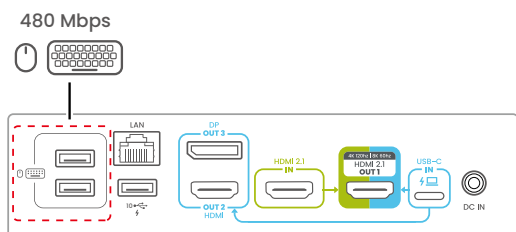

Ethernet

Connect a router to the LAN port, which supports speeds of 10/100/1000 Mbps.

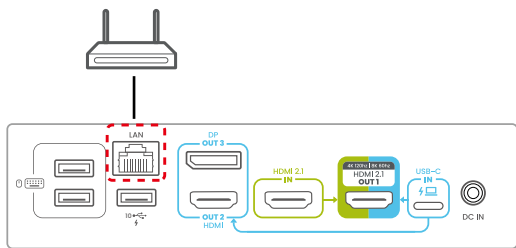

Audio in & out

Connect a headset, microphone or other audio devices to the audio port.

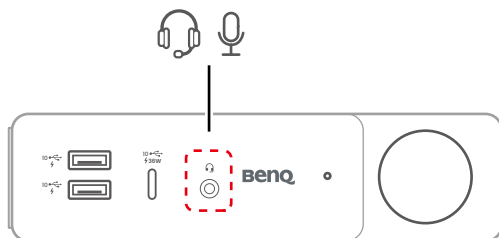

Product information

Specifications

Model name	DP1310
Dimension & Weight	
Dimension (mm)	156 x 103 x 40 (mm)
Weight	550 g
Power	
AC input	110V-240V ~ 47Hz-63Hz
DC output	20V/9A, 180W
Connect to Host	
USB-C Connector (10Gbps, PD 100W charging) Rear	1
HDMI Connector (HDMI 2.1, backward compatible with HDMI 2.0 and earlier ver.) Rear	1
Video output	
HDMI 2.1 (OUT 1) Rear	1
HDMI 2.0 (OUT 2) Rear	1
DisplayPort 1.2 (OUT 3) Rear	1
Audio	
3.5mm Audio Jack (IN/OUT) compatible with OMTP & CTIA Front	1
Networking	
Gigabit Ethernet RJ-45 (10/100/1000M) Rear	1
USB to Devices	
USB-C Connector (10Gbps, PD36W charging) Front	1
USB-A Connector (10Gbps, BC1.2 7.5W charging) Front	2
USB-A Connector (10Gbps, BC1.2 7.5W charging) Rear	1
USB-A Connector (480Mbps for Keyboard & Mouse) Rear	2
Requirement	
System	Windows: 10+ macOS: 11.5+ Linux: Ubuntu 14.04+ Android: 5.0+ ChromeOS: R55 Build+
Operation Temperature	0°C to 40°C (32°F to 104°F)
Storage Temperature	-20°C to 60°C (-4°F to 140°F)

Model name	DP1310
In the Box	
beCreatus DP1310 USB-C Hybrid Dock	1
USB-C Cable	1 (1m, 3.28 ft.)
HDMI 2.1 Cable	1
180W Power Adapter & Power Cable	1

Notes

Specifications and functions are subject to change without notice

Troubleshooting

If your problems remain after checking this manual, please visit the local website from [Support.BenQ.com](https://support.benq.com) for more support and local customer service.

Charging & power issue

Problem	Solution
DP1310 can't be turned on.	<p>If the product cannot be turned on, try the following:</p> <ul style="list-style-type: none">• Use the attached power adapter & power cord DP1310 is equipped with 180W power adapter. In order to optimize the performance of the product, use the power adapter and power cord in the box and plug the power cord to a power outlet.• Power on the product Long press the round power button at the front of the product for three seconds to power on.
Why isn't DP1310 charging my laptop? Why is it charging so slowly?	<p>If your docking station is not charging your laptop or is charging in slow speed, try the following:</p> <ul style="list-style-type: none">• Use the provided power adapter & power cord DP1310 is equipped with 180W power adapter. Adapters of other brands may not support charging DP1310 at its maximum capacity. In order to optimize the performance of the product, use the power adapter and power cord in the box and plug the power cord to a power outlet.• Power on the product To use DP1310 to charge your laptop, long press the round power button at the front of DP1310 for three seconds to power on. The LED at the front of the product will light up.• Check the spec of the USB-C port on your laptop Not every laptop supports charging through USB-C port. Check if your connected laptop supports Power Delivery via USB-C port and verify which USB-C port (if more than one) supports Power Delivery.

Internet issue

Problem	Solution
What should I do if the dock's Ethernet port is not working?	<p>If your laptop cannot be connected to the Internet through the Ethernet port of BenQ DP1310, try the following:</p> <ul style="list-style-type: none">• Update your DisplayLink Driver Go to https://benqurl.biz/dock-driver to download the latest DisplayLink Driver for your docking station.• Checking the Ethernet port and the connected LAN cable Ensure that the LAN cable is connected firmly to the Ethernet port. The two LEDs from the port should light up solid green and blinking yellow. If not, try with a different LAN cable to see if the issue persists.

Cable issue

Problem	Solution
Is there any difference between the provided HDMI & USB-C cable and the ordinary ones? Why should I use them?	<ul style="list-style-type: none">• HDMI cable The provided BenQ HDMI cable is certified by the HDMI Licensing Administrator, Inc. to comply with HDMI 2.1, supporting up to 48 Gbps transmission speed. To enjoy the best display performance, make sure to use the provided HDMI 2.1 cable if your input source such as PS5, Xbox Series X/S supports HDMI 2.1.• USB-C cable The provided BenQ USB-C cable is the USB 3.2 series cable that supports up to 20 Gbps transfer speed, 100W power delivery and 4K 60Hz display performance. Make sure to use the provided cable for the best product experience.

DisplayLink issue

Problem	Solution
How can I download/update/delete DisplayLink Driver for the dock?	See below to learn how to download, update or delete DisplayLink Driver: <ul style="list-style-type: none">• Download DisplayLink Driver Go to the following URL to download the driver: https://benqurl.biz/dock-driver.• Update DisplayLink Driver DisplayLink Driver supports auto update through Microsoft Store for Windows 11 or later. If your auto update fails, check whether it's blocked by your firewall. Auto update is not available for Windows 10 and earlier version or macOS.• Delete DisplayLink Driver Learn how to delete the driver.

Audio issue

Problem	Solution
3.5 mm audio port is not working.	The audio port of DP1310 only receives audio from the USB-C IN port, which is normally connected to your laptop. If no sound is heard from your 3.5 mm audio device (e.g. headphone or headset) connected to the product's audio port, try the following: <ul style="list-style-type: none">• Audio for USB-C IN port Ensure that the audio output source on your laptop is set to BenQ DP1310 Audio.<ol style="list-style-type: none">A.Windows: Click the sound icon in the toolbar and choose BenQ DP1310 Audio in the drop-down menu.B.macOS: Click the Control Center icon in the menu bar and select Sound. Choose BenQ DP1310 Audio as the audio output.• Audio for HDMI 2.1 IN port To play audio of a gaming console or PC connected to the HDMI 2.1 IN source, use the display's built-in speakers or connect your audio device to the display.

Video issue

Problem	Solution
Why is my display showing black screen when connecting through DP1310?	<p>If you experience one or more black screen when connecting your laptop with DP1310, try the following:</p> <ul style="list-style-type: none">• Connection Make sure you've connected the product and your devices correctly, see Connecting displays on page 3 & Connecting dual inputs on page 4.• Laptop Ensure that the USB-C port of your laptop supports DisplayPort Alt Mode (DP Alt Mode) or try to connect using another laptop that supports DP Alt Mode.• Driver Make sure you've download the latest driver from DisplayLink.• Cable The quality of cable is highly related to the display quality. Make sure to use the provided HDMI 2.1 & USB-C cable or try replacing your current HDMI & DP cable to solve the black screen issue.
Signals from HDMI IN cannot be displayed on the external display.	<p>If you experience a black screen when connecting your HDMI input source to DP1310, try the following:</p> <ul style="list-style-type: none">• Connection Make sure you've connected the product and your devices correctly, see Connecting displays on page 3 & Connecting dual inputs on page 4.• Use the provided cable Make sure to use the provided certified HDMI 2.1 cable or try replacing your current HDMI cable to solve the display issue.• Use the source switch button to switch input source Check your currently displaying input source through the color of LED at the front of the product. See Switching input source on page 5.